

# PRICE LIST 2023

valid from 1st October 2022 until 31th March 2023



ROAD SWEEPERS  
SNOW BLADES  
VEHICLES



# TABLE OF CONTENTS

## TUCHEL-SWEEP

### ROAD SWEEPERS

2	SIMPLEX	Ø 400 mm
3	KOMPAKT	Ø 520 mm
4	ECO Pro	Ø 520 mm
5	PLUS 590	Ø 590 mm
6	PROFI 660	Ø 660 mm
7	PROFI-CHAMP	Ø 750 mm
8	PROFI-GIGANT 920	Ø 920 mm
9	BIG	Ø 600 mm
10	IDEAL 650	Ø 650 mm
11	SOLO	
12	WB 750 & HYDRO DIRVE	

## TUCHEL-SNOW

### SNOW BLADES

13	L-SK	I 50 cm
14	SK-K	I 70 cm
15	SK-F	I 70 cm
16	L-SF	I 82 cm
17	SF	I 103 cm
18	VARIO	I see catalogue
19	SALT SPREADER TS 120/200	

## TUCHEL-TRAC

### VEHICLES

20	TUCHEL-TRAC TRIO
21	TUCHEL-TRAC TRIO ATTACHMENTS
22	TUCHEL-TRAC MINI 3 / ATTACHMENTS
23	TUCHEL-TOOL FARM-CLEAN / ATTACHMENTS

24	TECHNICAL DATA SHEET „A-FRAME“, „THREE-POINT LINKAGE“ & „3-D LEVELLING“
25	TECHNICAL DATA SHEET BRUSH & „HYDRAULIC COUPLINGS“
26	CONTACT

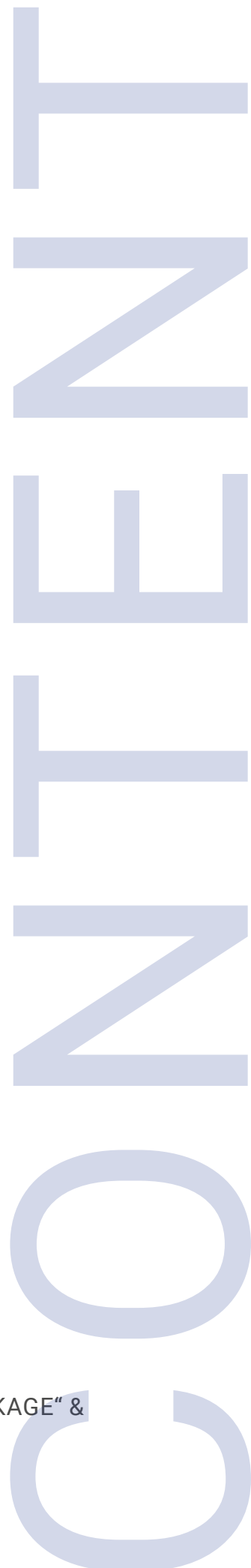

### BASIC MACHINE (free-sweeping)

WORKING WIDTH IN ANGLED POSITION

120 cm 135 cm 150 cm

113 cm 127 cm 141 cm

- 1162 Road sweeper with mechanical angling, brush **Ø 400 mm** with one 100 % PP brush full bristles, brush adjustment via spindle, support wheels Ø 180 x 50 mm, optionally with **mechanical** or **hydraulic drive**, gearbox angle adjustable (PTO shaft included in scope of delivery), max. height of the PTO on the vehicle 40 cm

#### ATTACHMENT

**A-frame** CAT communal / () with mounting bracket FIX (see Page 24)

**Three-point linkage** CAT I / II with mounting bracket FIX (see Page 24)

Attachment for **Tuchel-Trac TRIO** with mounting bracket FIX

Attachment for **Front mower** (direct mounting - adjustment required) with mounting bracket FIX

including attachment:

3,529 3,723 3,849

#### OPTIONS

<b>3D-run attachment system</b> (integrated side levelling)			203
<b>attachment for yard loader or municipal vehicles</b> including 3D-run attachment system			253
<b>brush Ø 400 mm</b>			
» 50 % PP / 50 % corrugated wire brush (do not use in agricultural area)	83	90	100
» 100 % PP snow brush (winter service)	71	79	87
<b>splash guard</b> extra long & adjustable (winter service)	240	254	271
<b>collecting container</b> with PU-lip, hydraulic emptying (double-acting hydraulic circuit required) with shut-off cock (mechanical) for free-sweeping operation (no dismounting required), integrated 3rd support wheel Ø 180 x 50 mm & levelling on the mounting bracket to compensate ground unevenness	1,237	1,302	1,336
<b>hydraulic angling</b> a double-acting hydraulic circuit is required (cannot be coupled with other functions)			472
<b>electro-magnetic commutator</b> 12/24 V, for vehicles with only one double-acting hydraulic circuit			697
<b>side brush</b> (right/left) brush Ø 500 mm with 100 % PP, hydraulic with spring element and speed regulation, a single-acting or a double-acting hydraulic circuit required (can be coupled with hydraulic emptying and/or hydraulic drive)			1,258
<b>water-spray system</b> 12/24 V dry running pump and switch box			
» 100-litre water tank with rear three-point (CAT I / II) for tank bearing			1,922
» without water tank			899
» on side brush			106
<b>limiting lights</b> (LED) acc. to StVZO (road traffic licensing authority) when driving in road traffic			345
<b>signal flag holder and signal flags</b> (price per pair)			122
<b>special colour</b> according to RAL (standard RAL 2004)			304

#### IMPORTANT

Please state when placing an order:

**PTO turning speed, PTO turning direction, universal PTO profile and attachment system!**

Transport & Packaging (net)	210	220	240
Our prices are ex works!			

### BASIC MACHINE (free-sweeping)

WORKING WIDTH IN ANGLED POSITION

135 cm 150 cm 175 cm 200 cm  
127 cm 141 cm 165 cm 188 cm

- 1752 Road sweeper with mechanical angling, brush **Ø 520 mm** with 100 % PP-Beeline  
Brush rings in honeycomb shape, easy brush adjustment via adjusting lever, support wheels Ø 200 x 50 mm, optionally with **mechanical** or **hydraulic drive**, gearbox angle adjustable  
(PTO shaft included in scope of delivery), max. height of the PTO on the vehicle 47 cm

#### ATTACHMENT

**A-frame** CAT communal / () with mounting bracket FIX (see Page 24)

**Three-point linkage** CAT I / II with mounting bracket FIX (see Page 24)

Attachment for **Tuchel-Trac TRIO** with mounting bracket FIX

Attachment for **Front mower** (direct mounting - adjustment required) with mounting bracket FIX

including attachment:

4 465 4 560 4 734 4 938

#### OPTIONS

<b>3D-run attachment system</b> (integrated side levelling)					224
<b>attachment for yard loader or municipal vehicles</b> including 3D-run attachment system					374
<b>brush Ø 520 mm</b>					
» 50 % PP / 50 % corrugated wire rings (do not use in agricultural area)	94	110	126		143
» 100 % PP snow brush (winter service)	84	100	116		130
<b>splash guard</b> extra long & adjustable (winter service)					258
<b>collecting container</b> with PU-lip, hydraulic emptying (double-acting hydraulic circuit required) with shut-off cock (mechanical) for free-sweeping operation (no dismounting required), integrated 3rd support wheel Ø 200 x 50 mm & levelling on the mounting bracket to compensate ground unevenness	1,261	1,318	1,374		1,430
» <b>High-fill flap</b> in collecting container, approx. 30 % more filling volume	92	92	130		130
<b>3. Support wheel</b> for free-sweeping road sweeper, height-adjustable, Ø 200 x 50 mm					294
<b>hydraulic angling</b> a double-acting hydraulic circuit is required (cannot be coupled with other functions)					472
<b>electro-magnetic commutator</b> 12/24 V, for vehicles with only one double-acting hydraulic circuit					697
<b>side brush</b> (right/left) brush Ø 600 mm with 100 % PP, hydraulic with spring element and speed regulation, a single-acting or a double-acting hydraulic circuit required (can be coupled with hydraulic emptying and/or hydraulic drive)					1,352
<b>water-spray system</b> 12/24 V dry running pump and switch box					
» 100-litre water tank built up on the machine					1,532
» 100-litre water tank with rear three-point (CAT I / II) for tank bearing					1,922
» without water tank, with dry running pump and switch box					899
» on side brush					106
<b>extra strong wheels</b> Ø 200 x 50 mm, steel welded, for heavy duty				piece	138
<b>limiting lights</b> (LED) acc. to StVZO (road traffic licensing authority) when driving in road traffic					345
<b>signal flag holder and signal flags</b> (price per pair)					122
<b>special colour</b> according to RAL (standard RAL 2004)					304

#### IMPORTANT

Please state when placing an order:

**PTO turning speed, PTO turning direction, PTO profile and attachment system!**

Transport & Packaging (net)	220	240	255	280
Our prices are ex works!				

## BASIC MACHINE (free-sweeping)

WORKING WIDTH IN ANGLED POSITION

135 cm 150 cm 180 cm 230 cm  
127 cm 141 cm 169 cm 211 cm

- 1353 Front and rear sweeper with mechanical angling, brush Ø 520mm with 100 % PP  
Brush with full bristles, easy brush adjustment via locking system with optimized sweeping angle,  
Castor wheels Ø 200 x 50 mm, **hydraulic** drive via powerful hydraulic motor & splash guard

2 268 2 342 2 453 2 651

### ATTACHMENT

<b>A-frame</b> CAT communal / 0 / I, swivel console with levelling system & screwed gibs (see Page 24)	930
<b>Three-point linkage</b> CAT I / II, rigid attachment (see Page 24) front/rear attachment	516
<b>Fork-tines attachment</b> 150 x 60 mm	
» Swivel console with parallelogram and height indicator; incl. quick lock system	1,073
» Surcharge for bigger fork-tine pockets (200 x 100 mm)	219
<b>Yard loader attachment</b> or front loader attachment, swivel console with parallelogram & side levelling, incl. height indicator	1,175
<b>Side levelling</b> for lateral compensation	269

### OPTIONS

<b>brush</b> Ø 520 mm				
» 50 % flat steel / 50 % PP brush (do not use in agricultural area)	223	248	273	310
» 100 % PP snow brush (winter service)	91	103	114	129
» 100 % PP brush rings in honeycomb shape, high endurance due to particularly dense brush, very suitable for coarse dirt (in case of retrofit, consider a different roller shaft, price on request)	189	204	222	240
<b>splash guard</b> for free-sweeping version, extra long (380 mm) with anti-skid flap (winter service)	315	315	336	348
<b>collecting container</b> with PU-lip, hydraulic emptying (double-acting hydraulic circuit required) with shut-off cock (mechanical) for free-sweeping operation (no dismounting required)	1,313	1,376	1,418	1,487
<b>3. Support wheel</b> only for front attachment Ø 200 x 50 mm (required for all attachments with parallelogram)				455
<b>hydraulic angling</b> (an additional double-acting hydraulic circuit or EM changeover required)				559
<b>electro-magnetic commutator</b> (EM) 12/24 V (per additional hydraulic function) for vehicles with only one double-acting hydraulic circuit				887
<b>side brush</b> (right/left) brush Ø 600 mm with 100 % PP, Spring element & shut-off cock (mechanical), (can be coupled with hydraulic emptying and / or hydraulic drive) only possible in connection with collecting container				1,319
<b>water-spray system</b> 12/24 volt dry running pump and switch box				
» 100-litre water tank				1,532
» 200-litre water tank (from 180 cm)				1,768
» without water tank				1,014
» inclusive on side brush (if ordered)				—
<b>extra strong wheels</b> Ø 200 x 50 mm, steel welded, for heavy duty			piece	138
<b>special colour</b> according to RAL (standard RAL 2004)				304

Transport & Packaging (net)	210	240	255	280
-----------------------------	-----	-----	-----	-----

Our prices are ex works!

## BASIC MACHINE (free-sweeping)

WORKING WIDTH IN ANGLED POSITION

135 cm 150 cm 180 cm 200 cm 230 cm 260 cm  
127 cm 141 cm 169 cm 187 cm 216 cm 244 cm

1382 Front and rear sweeper with sturdy base frame with mounting device, mechanical angling, brush Ø 590 mm with 100% PP WaveLine combination bristles with CrownLock system (optimal dirt collecting & high endurance), easy brush adjustment via adjusting lever with optimized sweeping angle, brush after-running regulation, castor wheels Ø 250 x 50 mm & hydraulic drive via powerful hydraulic motor

3 383 3 514 3 685 3 856 4 718 4 884

### ATTACHMENT

<b>A-frame</b> CAT communal / 0 / I swivel console with levelling system & screwed gibs (see Page 24)	930
<b>Three-point linkage</b> CAT I / II rigid attachment, front/rear attachment (see Page 24)	516
» Spherical bearing for optimal ground adjustment (three-point linkage front attachment)	157
<b>Fork-tines attachment</b> 150 x 60 mm	
» Swivel console with parallelogram and height indicator; incl. quick lock system	1,073
» 3D-run attachment system with roller shaft, side levelling, Quick lock system & height indicator (=centre position in side levelling see Page 24)	1,766
» Surcharge for bigger fork-tine pockets (200 x 100 mm)	219
<b>Yard loader attachment</b> or front loader attachment, swivel console with parallelogram, side levelling, incl. height indicator	1,175
» „Smart Attach“ Complete hydraulic quick hitch	on request
<b>Wheel loader/telescopic loader attachment</b> (quick hitch system) 3D-run attachment system with roller shaft, Side levelling and height indicator (=centre position in side levelling see Page 24)	1,942
<b>Municipal vehicle attachment</b> (Multicar, ...) Swivel console with levelling system & screwed gibs, incl. lateral side levelling	1,765
<b>Attachment plate with lifting</b> including reinforced swivel console, excavation cylinder with pressure limit, Level / side levelling and transport locking device (from 200cm possible) fits with Unimog front mounting attachment DIN 76060	
» Shape B (size 3) with fastening via swivelling screws M30 or clamping screws M24	
» Shape A (size 5) with fastening via swivelling screws M30	3,486
<b>Side levelling</b> for lateral compensation (not required for wheel loader and telescopic loader attachment)	269

### OPTIONS

<b>internal motor</b>	642
<b>brush</b> Ø 590 mm, 100 % PP brush rings in honeycomb shape	
» 50 % PP / 50 % corrugated wire rings	119 119 171 171 without surcharge
» 100 % Snowline brush rings in honeycomb shape (winter service)	58 58 87 87 224 224 112 112
<b>splash guard</b> for free-sweeping version, extra long (380 mm) with anti-skid flap (winter service)	315 315 336 336 348 362
<b>collecting container</b> with PU-lip, hydraulic emptying (double-acting hydraulic circuit required) with shut-off cock (mechanical) for free-sweeping operation (no dismounting required)	1,493 1,520 1,551 1,581 1,608 1,656
» <b>High-fill flap</b> in container, approx. 30% more filling volume	92 92 130 130 130 215
<b>3. Support wheel</b> only for front attachment Ø 250 x 50 mm (required for all attachments with parallelogram and roller shaft), short version for machines without collecting container also available	461
<b>hydraulic angling</b> (an additional double-acting hydraulic circuit or EM changeover required)	559
<b>electro-magnetic commutator</b> (EM) 12/24 V (per additional hydraulic function) for vehicles with only one double-acting hydraulic circuit	887
<b>side brush</b> (right/left) brush Ø 600 mm with 100 % PP, Spring element, speed regulation, shut-off cock (mechanical) and quick acting closure bar (can be coupled with hydraulic emptying and / or hydraulic drive) only possible in connection with collecting container	1,333
<b>water-spray system</b> 12/24 volt dry running pump and switch box	
» 100-litre water tank	1,532
» 200-litre water tank (from 150 cm)	1,768
» without water tank	1,014
» inclusive on side brush (if ordered)	—
<b>oil flow controller</b> for infinitely variable speed regulation with pressure control valve (from 160 bar)	
» 90-129 litres with pump capacity above 90 l/min required	804
» from 130-litre 1" connections; required for pump capacity above 130 l/min	1,320
<b>brush comb</b> removes light swept material from the brush (pin length 3.5 cm)	356 369 394 413 550 595
<b>extra strong wheels</b> Ø 250 x 80 mm, steel welded, for heavy duty (recommended from 260 cm)	piece 168
<b>limiting lights</b> (LED) acc. to StVZO (road traffic licensing authority) when driving in road traffic	345
<b>signal flag holder and signal flags</b> (price per pair)	122
<b>special colour</b> according to RAL (standard RAL 2004)	304
Transport & Packaging (net)	220 230 255 280 305 375

Our prices are ex works!

## BASIC MACHINE (free-sweeping)

WORKING WIDTH IN ANGLED POSITION

200 cm 230 cm 260 cm 280 cm  
188 cm 216 cm 244 cm 260 cm

1552 Road sweeper with sturdy base frame & mounting device, mechanical angling, brush  $\varnothing$  660 mm with 100% PP WaveLine combination bristles with CrownLock system (high endurance due to particularly dense brush), easy brush adjustment via adjusting lever with optimized sweeping angle, hydro block incl. pressure relief valve (from 160 bar) and brush after-running regulation, castor wheels  $\varnothing$  250 x 80 mm & **hydraulic** drive via internal, powerful hydraulic motor

5 668 5 842 6 861 8 297

### ATTACHMENT

<b>A-frame</b> CAT I incl. 3D-run attachment system with roller shaft, levelling system and height indicator (=centre position in side levelling see Page 24)	1,756
<b>Three-point linkage</b> CAT I / II incl. 3D-run attachment system with roller shaft, levelling system and height indicator (=centre position in side levelling see Page 24)	1,912
<b>Fork-tines attachment</b> 150 x 60 mm » incl. 3D-run attachment system with roller shaft, levelling system, quick lock system & height indicator (=centre position in side levelling see Page 24) » Surcharge for bigger fork-tine pockets (200 x 100 mm)	2,125 219
<b>Wheel loader/telescopic loader attachment</b> (quick hitch system) 3D-run attachment system with roller shaft, Side levelling and height indicator (=centre position in side levelling see Page 24)	2,203
<b>Attachment plate with lifting</b> including reinforced swivel console, excavation cylinder with pressure limit, Level / side levelling and transport locking device, fits with <b>Unimog front mounting attachment DIN 76060</b> » Shape B (size 3) with fastening via swivelling screws M30 or clamping screws M24 » Shape A (size 5) with fastening via swivelling screws M30	3,571
<b>Combi attachment</b> various combinations possible	on request

### OPTIONS

<b>brush</b> $\varnothing$ 660 mm » 100 % PP brush rings in honeycomb shape » 50 % PP / 50 % corrugated wire rings » 100% Snowline brush rings in honeycomb shape (winter service)					without surcharge
	202	215	227	242	
	101	114	127	142	
<b>splash guard</b> for free-sweeping version, extra long (380 mm) with anti-skid flap (winter service)	340	352	367	388	
<b>collecting container</b> with PU-lip, hydraulic emptying with shut-off cock (mechanical) for free-sweeping operation (no dismantling required), High-fill flap in container (approx. 30% more filling volume) & integrated 3rd support wheel, $\varnothing$ 250 x 80 mm	1,853	1,903	1,984	2,018	
<b>3. Support wheel</b> $\varnothing$ 250 X 80 mm (only with free-sweeping insert)				699	
<b>hydraulic angling</b> (an additional double-acting hydraulic circuit or EM changeover required)				559	
<b>electro-magnetic commutator</b> (EM) 12/24 V (per additional hydraulic function) for vehicles with only one double-acting hydraulic circuit				887	
<b>side brush</b> (right/left) brush $\varnothing$ 600 mm with 50 % PP / 50 % flat steel (other brushes on request), Spring element, speed regulation, shut-off cock (mechanical) & quick acting closure bar (can be coupled with hydraulic emptying and / or hydraulic drive) only possible in connection with collecting container » <b>hydraulic opening</b> (one additional, double-acting hydraulic circuit or EM changeover required)				1,489 599	
<b>water-spray system</b> 12/24 volt dry running pump and switch box » 200-litre water tank » without water tank » inclusive on side brush (if ordered)				1,768 1,014	
<b>oil flow controller</b> for infinitely variable speed regulation with pressure control valve (from 160 bar) » 90-129 litres with pump capacity above 90 l/min required » from 130-litre 1" connections; required for pump capacity above 130 l/min				804 1,320	
<b>brush comb</b> removes light swept material from the brush (pin length 3.5 cm)	413	550	595	650	
<b>scrape device</b> straight shape with hydraulic operation (2 hydr. cylinders) for use with & without collecting container, optimal ground adjustment through spring-loaded shares (usable & adjustable on both sides) dirt is led to the road sweeper (not possible in connection with side brush)	3,098	3,603	4,044	4,361	
<b>CSE tyres</b> $\varnothing$ 306 x 116 mm			piece	430	
<b>limiting lights</b> (LED) acc. to StVZO (road traffic licensing authority) when driving in road traffic				345	
<b>signal flag holder and signal flags</b> (price per pair)				122	
<b>special colour</b> according to RAL (standard RAL 2004)				304	

Transport & Packaging (net)	340	370	445	495
-----------------------------	-----	-----	-----	-----

Our prices are ex works!



# BASIC MACHINE (free-sweeping)

WORKING WIDTH IN ANGLED POSITION

210 cm 240 cm 280 cm  
195 cm 225 cm 255 cm

1561 Front and rear sweeper with sturdy base frame & mounting device, mechanical angling, Brush  $\varnothing$  750 mm with 100% PP WaveLine brush with CrownLock system (high endurance due to particularly dense brush), easy brush adjustment via adjusting lever with optimized sweeping angle, hydro block incl. pressure relief valve (from 160 bar) and brush after-running regulation, castor wheels  $\varnothing$  405 x 110mm & **hydraulic** drive via internal, powerful hydraulic motor

8 623 8 817 8 977

## ATTACHMENT

**A-frame** CAT I incl. 3D-run attachment system with roller shaft, levelling system and height indicator (=centre position in side levelling see Page 24) 2,372

### Three-point linkage CAT I / II

- » Front: 3D-run attachment system with roller shaft, levelling system & height indicator (=centre position in side levelling see Page 24) 2,372
- » Rear: rigid attachment, swivelling via rotating assembly (see Page 24) 1,948

### Fork-tines attachment 150 x 60 mm

- » incl. 3D-run attachment system with roller shaft, levelling system, quick lock system & height indicator (=centre position in side levelling see Page 24) 3,029
- » Surcharge for bigger fork-tine pockets (200 x 100 mm) 219

**Wheel loader/telescopic loader attachment** (quick hitch system) 3D-run attachment system with roller shaft, Side levelling and height indicator (=centre position in side levelling see Page 24) 2,405

**Attachment plate with lifting** including reinforced swivel console, excavation cylinder with pressure limit, Level / side levelling and transport locking device, fits with **Unimog front mounting attachment DIN 76060**

- » Shape B (size 3) with fastening via swivelling screws M30 or clamping screws M24
- » Shape A (size 5) with fastening via swivelling screws M30 3,759

**Combi attachment** various combinations possible on request

## OPTIONS

<b>brush</b> $\varnothing$ 750 mm			
» 50 % PP / 50 % corrugated wire rings	228	247	267
» 100% Snowline brush rings in honeycomb shape (winter service)	113	129	148
<b>splash guard</b> for free-sweeping version, extra long (500 mm) with anti-skid flap (winter service)	367	378	388
<b>collecting container</b> with PU-lip, hydraulic emptying with shut-off cock (mechanical) for free-sweeping operation (no dismantling required), High-fill flap in container (approx. 30% more filling volume) & integrated 3rd support wheel, $\varnothing$ 405 x 110 mm	2,334	2,380	2,446
» Three-point rear attachment variant: without 3rd support wheel (a 3rd support wheel is required for a change to front attachment)		1,517	1,594
<b>3. Support wheel</b> $\varnothing$ 405 X 110 mm (only with free-sweeping insert and three-point rear attachment variant)			865
<b>hydraulic angling</b> (an additional double-acting hydraulic circuit or EM changeover required)			559
<b>electro-magnetic commutator</b> (EM) 12/24 V (per additional hydraulic function) for vehicles with only one double-acting hydraulic circuit			887
<b>side brush</b> (right/left) brush $\varnothing$ 750 mm with 50 % PP / 50 % flat steel (other brushes on request), Spring element, speed regulation, shut-off cock (mechanical) & quick acting closure bar (can be coupled with hydraulic emptying and / or hydraulic drive) only possible in connection with dirt collection container			1,602
» <b>hydraulic opening</b> (one additional, double-acting hydraulic circuit or EM changeover required)			599
<b>water-spray system</b> 12/24 volt dry running pump and switch box			
» 200-litre water tank			1,768
» 400-litre tank			2,910
» without water tank			1,014
» inclusive on side brush (if ordered)			
<b>High Pressure Pump</b> hydraulic driven approx. 220 bar / 50 litre/minute water ramp V2A (stainless steel) incl. high pressure nozzles, filter, hose drum 20m & high pressure lance V2A (stainless steel), change from water tank to external filling possible			on request
<b>oil flow controller</b> for infinitely variable speed regulation with pressure control valve (from 160 bar)			
» 90-129 litres with pump capacity above 90 l/min required			804
» from 130-litre 1" connections; required for pump capacity above 130 l/min			1,320
<b>brush comb</b> removes light swept material from the brush (pin length 3.5 cm)	489	576	650
<b>scrape device</b> pointed shape with hydraulic operation (2 hydr. cylinders) for use with & without collecting container, height-adjustable via spindle, optimal ground adjustment through spring-loaded shares (usable & adjustable on both sides) dirt is led to the road sweeper (not possible in connection with side brush)		5,041	5,424
<b>extra strong wheels</b> $\varnothing$ 410 x 145 mm, for heavy duty		piece	649
<b>limiting lights</b> (LED) acc. to StVZO (road traffic licensing authority) when driving in road traffic			345
<b>signal flag holder and signal flags</b> (price per pair)			122
<b>special colour</b> according to RAL (standard RAL 2004)			496
Transport & Packaging (net)	385	470	535

Our prices are ex works!

Equipment only valid for initial equipment, in case of retrofit, please call for prices! Special accessories on request.  
No responsibility is accepted for the accuracy of this information. All Prices in euro plus legal VAT, valid until 31th March 2023.



## BASIC MACHINE (free-sweeping)

WORKING WIDTH IN ANGLED POSITION

260 cm 290 cm 320 cm 350 cm  
237 cm 265 cm 292 cm 320 cm

- 1582 Road sweeper with 3-D levelling (swivel console with side levelling and roller shaft), mechanical angling, brush **Ø 920 mm**, with 100 % PP brush rings in honeycomb shape (high endurance due to particularly dense brush), easy brush adjustment via adjusting lever with optimized sweeping angle, Brush after-running regulation, castor wheels  $\varnothing$  410 x 145 mm, **hydraulic** drive via 2 internal hydraulic motors (incl. oil flow controller > 90 litres, 1" hydraulic connections) & splash guard

20,158 20,996 21,512 22,030

### ATTACHMENT

**Three-point linkage** CAT I / II

with side levelling and height indicator (=centre position in side levelling see Page 24)

2,546

**Wheel loader / telescopic loader attachment** (quick hitch)

with side levelling and height indicator (=centre position in side levelling see Page 24)

3,130

### OPTIONS

**collecting container** with PU-lip,

hydraulic emptying with shut-off cock via 2 hydraulic cylinders (mechanical)

for free-sweeping operation (no dismantling required), high-fill flap in container

(approx. 30% more filling volume) & integrated **third and fourth castor wheel**  $\varnothing$  410 x 145 mm

6,733 7,162 7,687 7,994

**hydraulic angling**

via 2 cylinders with EM changeover required

2,595

**side brush** (right/left) brush  $\varnothing$  850 mm with 50 % PP / 50 % flat steel (other brushes on request),

speed regulation, shut-off cock (mechanical) & **hydraulic opening** with EM changeover

(can be coupled with hydraulic drive)

2,435

**water-spray system** with two 12/24 volt dry running pumps and switch box

» 400-litre water tank

2,910

» inclusive on side brush (if ordered)

—

**3rd and 4th support wheel**  $\varnothing$  410 X 145 mm (only with free-sweeping insert without collecting container)

2,844

**limiting lights** (LED) acc. to StVZO (road traffic licensing authority) when driving in road traffic

345

**signal flag holder and signal flags** (price per pair)

122

**special colour** according to RAL (standard RAL 2004)

586

Transport & Packaging (net)

590 610 645 665

Our prices are ex works!

## BASIC MACHINE

120 cm 150 cm 180 cm 210 cm

- 1781 Bucket sweeper, very well suitable for coarse dirt, brush **Ø 600 mm** 100 % PP Beeline brush rings  
Honeycomb shape (high endurance due to particularly dense brush bristles), big bucket for dirt collecting,  
Wear strips / blade firmly welded with bucket (increases service life of the bucket),  
**hydraulic** drive via internal, powerful hydraulic motor incl. overpressure protection,  
optimal ground pressure of the brush due to dead weight, easy brush adjustment

### ATTACHMENT

**Compact / wheel loader attachment** (quick hitch system)

including attachment:

5,164 5,688 6,173 7,641

### OPTIONS

<b>angle (appr. 25 degrees)</b> for optimising the tilting angle (for high emptying), firmly welded between bucket and quick hitch system					341
<b>brush Ø 600 mm</b> » 50 % PP / 50 % corrugated wire rings	155	155	194	194	
<b>reinforcement package for continuous operation</b> Wear strips made of armoured nub steel, screw-down blade bottom and lateral made of armoured nub steel 500 HB, double useful life due to easy turning over	564	612	671	826	
<b>cover opening</b> via 2 hydraulic cylinders (an additional double-acting hydraulic circuit required, only possible with initial equipment)					1,527
<b>electro-magnetic commutator</b> (EM) 12/24 V (per additional hydraulic function) for vehicles with only one double-acting hydraulic circuit					887
<b>side brush</b> (right/left) brush ø 600 mm with 50 % PP / 50 % flat steel, with shut-off cock (mechanical) can be coupled with hydraulic emptying and / or hydraulic drive					1,664
<b>water-spray system</b> 12/24 volt dry running pump and switch box » 100-litre water tank » 200-litre water tank (from 180 cm) » hydraulic cover opening with 100-litre water tank (from 150 cm) » hydraulic cover opening with 200-litre water tank (from 210 cm) » on side brush					1,532 1,768 1,532 1,768 106
<b>special colour</b> according to RAL (standard RAL 2004)					304

Transport & Packaging (net)

280 305 330 355

Our prices are ex works!

## BASIC MACHINE

130 cm 150 cm 180 cm 210 cm

- 1821 Road sweeper with one brush **ø 650 mm**, 100 % PP mixed brushes for coarse and fine dirt, oscillating brush with ground pressure setting, incl. 3rd support wheel, castor wheels  $\varnothing$  250 x 60 mm, large hydraulically drainable collecting container with PU-lip, dirt protection covering & **hydraulic** drive via internal, powerful hydraulic motor with double pressure relief valve

6,387 6,904 7,419 7,662

### ATTACHMENT

- 9005 **Fork-tines attachment** 150 x 70 mm  
 » incl. 3-D levelling quick lock system 1,351  
 » Surcharge for bigger fork-tine pockets (210 x 110 mm) 257

#### Combi attachment

- 9012 » Fork-tines attachment & wheel loader attachment (SWE) with 3-D levelling 1,971  
 9029 » Fork-tines attachment & three-point linkage 1,971

### OPTIONS

<b>side brush</b> $\varnothing$ 750 mm right/left Brush 100 % PP with shut-off cock (mechanical) (can be coupled with hydraulic emptying and / or hydraulic drive)	1,682
<b>water-spray system</b> 12/24 volt dry running pump and switch box » 100-litre water tank 1,532 » 200-litre water tank 1,768 » inclusive on side brush (if ordered) —	
<b>oil flow controller</b> for infinitely variable speed regulation with pressure control valve (from 160 bar) » 90-129 litres with pump capacity above 90 l/min required	804
<b>extra strong wheels</b> $\varnothing$ 250 x 80 mm, steel welded, for heavy duty	piece 168
<b>limiting lights</b> (LED) acc. to StVZO (road traffic licensing authority) when driving in road traffic	345
<b>special colour</b> according to RAL (standard RAL 2004)	304

### MACHINE-OWN HYDRAULIC SYSTEM with oil tank

- 9030 The own hydraulic system ensures independence from the carrier-vehicle.  
 No oil mixing when operating with several carrier-vehicles (up to **180 cm**)  
 » 13 PS Honda GX 390 petrol engine (please ask for delivery time) 5,475  
 » 10 HP Yanmar diesel engine 7,295

Transport & Packaging (net)	280	315	340	360
-----------------------------	-----	-----	-----	-----

Our prices are ex works!

## BASIC MACHINE

150 cm 190 cm 230 cm 250 cm 280 cm

1101 Free-sweeping push broom with sturdy base frame 11 brush rows & parking supports (3 pcs.)

incl. <b>fork-tines attachment</b> 130 x 70 mm with safety chain	1,829	2,216	2,607	2,844	3,086
» Surcharge for <b>bigger fork-tine pockets</b> , screwed (200 x 100 mm)					219

### ATTACHMENT

<b>A-frame</b> CAT I (see page 24)	533
<b>Three-point linkage</b> CAT I / II rigid attachment (see Page 24)	533
<b>Hitch system for buckets</b>	533
<b>Gripping bucket</b>	998
<b>Yard loader attachment</b> or front loader attachment (up to 0.4 m³)	1,143
<b>excavator attachment</b> (MS 03, other attachment on request)	738

### OPTIONS

<b>side bristle</b> for clean the border	
» right or left	234
» right and left	467
<b>special colour</b> according to RAL (standard RAL 2004)	304

Transport & Packaging (net)	175	195	220	290
-----------------------------	-----	-----	-----	-----

Our prices are ex works!

### BASIC MACHINE

for wheel loader / municipal vehicles / tractors / yard loader

1911	Weed brush with one brush $\varnothing$ 750 mm with bundled <b>flat steel wire</b> , mechanical inclination adjustment (top link), mechanical lateral adjustment (pluggable), rubber protection cloth, parking support & <b>hydraulic drive</b>	3,709
------	---	-------

#### ATTACHMENT

<b>A-frame</b> CAT communal / 0 / I, rigid attachment (see Page 24)	387
<b>Three-point linkage</b> CAT I / II rigid attachment (see Page 24)	518
<b>Fork-tines attachment</b> 150 x 60 mm with rigid attachment	748
<b>Wheel loader/telescopic loader attachment</b> (quick hitch system) rigid attachment (see Page 24)	611
<b>Municipal vehicle attachment</b> (Multicar, ...) rigid attachment	518

#### OPTIONS

<b>brush</b> $\varnothing$ 750 mm <b>rope wrapping wire bundle</b> plastic sheathed, screwable, 22 pieces (surcharge)	
» for initial equipment	445
» Retrofitting with new brush disc for quick change	642
<b>guide wheel / support wheel</b> (infinitely height-adjustable)	
» with castor wheel 200 x 50 mm (< 0.4 m <sup>3</sup> bucket volume)	361
» with castor wheel 250 x 80 mm (< 0.4 m <sup>3</sup> bucket volume)	481
<b>hydraulic lateral adjustment</b> stroke 450 mm (1 additional DW required)	638
<b>hydraulic inclination adjustment</b> (1 additional DW required)	535
<b>electro-magnetic commutator</b> 12/24 V (6/2-way or 8/3-way) for vehicles with only one or two double acting hydraulic circuits	887
<b>speed regulation</b> for adjustment of the speed	190
<b>water-spray system</b> 12/24 V dry running pump, switch box, 100-litre water tank, 1 x spray nozzle	
» with rear three-point (CAT I / II) for tank bearing <b>or</b>	
» Tank bearing on Hydro Drive (see below)	1,922
<b>special colour</b> according to RAL (standard RAL 2004)	304

### BASIC MACHINE for excavators up to 6 t

1901	Weed brush with one brush $\varnothing$ 750 mm with bundled <b>flat steel wire</b> , mechanical inclination adjustment (top link), rubber protection cloth, parking support & <b>hydraulic drive</b>	
	without attachment:	3,240

#### OPTIONS

<b>excavator attachment</b> (MS01 / MS 03, other attachments on request)	230
--	-----

#### OPTIONS

<b>brush</b> $\varnothing$ 750 mm <b>rope wrapping wire bundle</b> plastic sheathed, screwable, 22 pieces (surcharge)	
» for initial equipment	445
<b>special colour</b> according to RAL (standard RAL 2004)	304

**IMPORTANT!** Please state when placing an order:  
**Number of hydraulic circuits / hydraulic performance**

### HYDRO DRIVE for vehicles which have no sufficient oil flow

1941	Oil tank with approx. 55-litre volume and oil sight glass for easy oil level control, oil filter for a good and constant oil quality, internal hydraulic pump, drive via PTO shaft, PTO turning speed:	
	» 540 rpm, approx. 32 l/min at 130 bar	
	» 1,000 rpm, approx. 60 l/min at 130 bar	
	<b>Three-point linkage</b> CAT I / II rigid attachment (see Page 24)	2,559

Transport & Packaging (net)	210
-----------------------------	-----

Our prices are ex works!

### SNOW BLADE

WORKING WIDTH IN ANGLED POSITION

125 cm 155 cm 185 cm

107 cm 133 cm 160 cm

1192 Base frame with **spring flap elements**, mechanical angling, height-adjustable skids & edge deflectors (right & left)

with **PU-lip** (blade height 50cm):

1,225 1,384 1,539

### ATTACHMENT

**A-frame** CAT communal / 0 incl. swivel console & screwed gibs (see Page 24)

647

» incl. side levelling

897

**Three-point linkage** CAT I / II incl. swivel console & screwed gibs (see Page 24)

815

» incl. side levelling

1,066

Attachment for **Tuchel-Trac TRIO** incl. swivel console & screwed gibs

647

» incl. side levelling

897

**Yard loader attachment** incl. swivel console & screwed gibs

1,093

**Fork-tines attachment** 150 x 60 mm incl. swivel console & screwed gibs

814

» incl. side levelling

1,064

### OPTIONS

**hydraulic angling**

(an additional double-acting hydraulic circuit)

479

**castor wheels** Ø 150 x 50 mm

are attached instead of skids (price per pair)

241

**limiting lights** (LED) acc. to StVZO (road traffic licensing authority) when driving in road traffic

345

**signal flag holder** (price per pair)

80

**signal flags** (price per pair)

41

**special colour** according to RAL (standard RAL 2004)

304

Transport & Packaging (net)

170

200

220

Our prices are ex works!

### SNOW BLADE

WORKING WIDTH IN ANGLED POSITION

150 cm 180 cm 200 cm 225 cm

132 cm 158 cm 176 cm 198 cm

1342 **Sturdy base frame & foldable shield** (as overrun fuse),  
mechanical angling, infinitely height-adjustable  
castor wheels Ø 200 x 50 mm & edge deflectors (right & left)

with **PU-lip** (blade height 70cm):

2,100 2,401 2,551 2,912

with **steel lip** (blade height 70 cm):

2,559 2,918 3,135 3,556

### ATTACHMENT

**A-frame** incl. swivel console, screwed gibs & side levelling (see Page 24)

» CAT communal / 0

1,049

» CAT I

1,095

**Three-point linkage** CAT I / II incl. swivel console, screwed gibs & side levelling (see Page 24)

1,095

**Yard loader attachment/Quick hitch** incl. swivel console, screwed gibs & side levelling,  
small roller guide, only for small wheel loaders (up to 0.8 m³ bucket volume)

1,608

**Municipal vehicle attachment** incl. swivel console with side levelling,  
Lift-out device on the vehicle side (Kommobil, Multicar, ...)

1,258

**Fork-tines attachment** 150 x 50 mm incl. swivel console, screwed gibs & side levelling

1,436

### OPTIONS

**hydraulic angling**

(an additional double-acting hydraulic circuit)

655

» with **pressure control valve**

880

**extra strong wheels** Ø 200 x 50 mm, steel welded, for heavy duty (price per pair)

275

**limiting lights** (LED) acc. to StVZO (road traffic licensing authority) when driving in road traffic

345

**signal flag holder** (price per pair)

80

**signal flags** (price per pair)

41

**special colour** according to RAL (standard RAL 2004)

304

Transport & Packaging (net)

225

240

260

285

Our prices are ex works!



### SNOW BLADE

WORKING WIDTH IN ANGLED POSITION

150 cm 180 cm 200 cm 225 cm

132 cm 154 cm 176 cm 198 cm

1342 **Sturdy base frame with spring flap elements**, mechanical angling, infinitely variable height-adjustable castor wheels Ø 200 x 50 mm & edge deflectors (right & left)

with **PU-lip** (blade height 70cm):

1,991 2,197 2,420 2,846

with **cummunal lip** highly wear resistant rubber lip with corundum inlay (blade height: 75 cm):

2,651 2,963 3,300 3,833

with **steel lip** (blade height 70 cm):

2,450 2,714 3,304 3,490

### ATTACHMENT

**A-frame** incl. swivel console, screwed gibs & side levelling (see Page 24)

» CAT communal / 0

1,049

» CAT I

1,095

**Three-point linkage** CAT I / II incl. swivel console, screwed gibs & side levelling (see Page 24)

1,095

**Yard loader attachment/Quick hitch** incl. swivel console, screwed gibs & side levelling, small roller guide, only for small wheel loaders (up to 0.8 m³ bucket volume)

1,608

**Municipal vehicle attachment** incl. swivel console with side levelling, Lift-out device on the vehicle side (Kommobil, Multicar, ...)

1,258

**Fork-tines attachment** 150 x 50 mm incl. swivel console, screwed gibs & side levelling

1,436

### OPTIONS

**hydraulic angling**

(a double-acting hydraulic circuit required)

655

» with pressure control valve

880

**extra strong wheels** Ø 200 x 50 mm, steel welded, for heavy duty (price per pair)

275

**limiting lights** (LED) acc. to StVZO (road traffic licensing authority) when driving in road traffic

345

**signal flag holder** (price per pair)

80

**signal flags** (price per pair)

41

**special colour** according to RAL (standard RAL 2004)

304

Transport & Packaging (net)

225

240

260

285

Our prices are ex works!

## SNOW BLADE

WORKING WIDTH IN ANGLED POSITION

200 cm 225 cm 250 cm 275 cm 300 cm  
175 cm 196 cm 218 cm 240 cm 262 cm

1371 **Sturdy base frame with spring flap elements**, mechanical angling, infinitely variable height-adjustable castor wheels Ø 200 x 80 mm & edge deflectors (right & left)

with <b>PU-lip</b> (blade height 82cm):	3,285	3,446	3,660	3,905	4,306
with <b>cummunal lip</b> highly wear resistant rubber lip with corundum inlay (blade height: 87 cm):	4,167	4,290	4,765	5,108	5,631
with <b>steel lip</b> (blade height 82 cm):	3,869	4,090	4,368	4,688	5,157

### ATTACHMENT

<b>A-frame</b> CAT I incl. swivel console (see page 24)					
» with screwed gibs for fixed attachment					1,260
» with side levelling					2,083
» with roller shaft (2-D levelling) and height indicator (=centre position in side levelling see Page 24)					1,837

<b>Three-point linkage</b> CAT I / II incl. swivel console (see Page 24)					
» with screwed gibs for fixed attachment					1,353
» with side levelling					2,176
» with roller shaft (2-D levelling) and height indicator (=centre position in side levelling see Page 24)					1,916

<b>Wheel loader / telescopic loader attachment</b> (quick hitch system) incl. swivel console with roller shaft (2-D levelling) & height indicator (=centre position in side levelling see Page 24)					2,052
--	--	--	--	--	-------

<b>Attachment plate with lifting</b> including swivel console, excavation cylinder with pressure limit, Level / side levelling and transport locking device fits with <b>Unimog front mounting attachment DIN 76060</b>					
» Shape B (size 3) with fastening via swivelling screws M30 or clamping screws M24					
» Shape A (size 5) with fastening via swivelling screws M30					3,181

<b>Fork-tines attachment</b> 150 x 50 mm incl. swivel console with screwed gibs					1,270
» with side levelling					2,092
» Surcharge for bigger fork-tine pockets (200 x 100 mm)					219

### OPTIONS

<b>hydraulic angling</b>					
Version with two hydraulic cylinders (one additional, double-acting hydraulic circuit)					965
» with <b>pressure control valve</b> (from 250 cm recommended)					1,231
» Surcharge for <b>pressure retention valve</b> (is additionally required for hydr. angling when in the hydraulic system of the vehicle there is not installed any pressure retention valve; often with Merlo)					366
<b>extra strong wheels</b> Ø 250 x 80 mm, for heavy duty (price per pair)					335
<b>snow guiding cloth</b> for good visibility of the driver	583	601	618	638	661
<b>limiting lights</b> (LED) acc. to StVZO (road traffic licensing authority) when driving in road traffic					345
<b>signal flag holder</b> (price per pair)					80
<b>signal flags</b> (price per pair)					41
<b>special colour</b> according to RAL (standard RAL 2004)					304

Transport & Packaging (net)	285	310	335	385	410
-----------------------------	-----	-----	-----	-----	-----

Our prices are ex works!

## SNOW BLADE

WORKING WIDTH IN ANGLED POSITION

250 cm 275 cm 300 cm 325 cm 350 cm  
219 cm 240 cm 262 cm 284 cm 306 cm

1332 **Sturdy base frame with spring flap elements**, mechanical angling,  
infinitely variable height-adjustable castor wheels Ø 250 x 80 mm & edge deflectors (right & left)

with <b>PU-lip</b> (blade height 103cm):	4,283	4,528	5,006	5,310	5,553
with <b>cummunal lip</b> highly wear resistant rubber lip with corundum inlay (blade height: 108 cm):	5,383	5,727	6,324	6,734	7,109
with <b>steel lip</b> (blade height 103 cm):	4,985	5,307	5,853	6,231	6,559

### ATTACHMENT

<b>A-frame</b> CAT I incl. swivel console (see page 24)					
» with screwed gibs for fixed attachment					1,260
» with side levelling					2,083
» with roller shaft (2-D levelling) and height indicator (=centre position in side levellingn see Page 24)					1,837
<b>Three-point linkage</b> CAT I / II incl. swivel console (see Page 24)					
» with screwed gibs for fixed attachment					1,353
» with side levelling					2,176
» with roller shaft (2-D levelling) and height indicator (=centre position in side levelling see Page 24)					1,916
<b>Wheel loader / telescopic loader attachment</b> (quick hitch system) incl. swivel console with roller shaft (2-D levelling) & height indicator (=centre position in side levelling see Page 24)					2,052
<b>Attachment plate with lifting</b> including swivel console, excavation cylinder with pressure limit, Level / side levelling and transport locking device fits with <b>Unimog front mounting attachment DIN 76060</b>					
» Shape B (size 3) with fastening via swivelling screws M30 or clamping screws M24					
» Shape A (size 5) with fastening via swivelling screws M30					3,181
<b>Fork-tines attachment</b> 150 x 50 mm incl. swivel console with screwed gibs					1,270
» with side levelling					2,092
» Surcharge for bigger fork-tine pockets (200 x 100 mm)					219

### OPTIONS

<b>hydraulic angling</b> Version with two hydraulic cylinders (one additional, double-acting hydraulic circuit)					965
» with <b>pressure control valve</b>					1,231
» with <b>pressure retention valve</b> (is additionally required for hydr. angling when in the hydraulic system of the vehicle there is not installed any pressure retention valve; often with Merlo)					1,331
<b>CSE tyres</b> Ø 306 x 116 mm (price per pair)					860
<b>skids</b> (price per pair)					1,093
<b>snow guiding cloth</b> for good visibility of the driver	618	638	661	677	691
<b>limiting lights</b> (LED) acc. to StVZO (road traffic licensing authority) when driving in road traffic					345
<b>signal flag holder</b> (price per pair)					80
<b>signal flags</b> (price per pair)					41
<b>special colour</b> according to RAL (standard RAL 2004)					304

Transport & Packaging (net)	335	385	410	425	495
-----------------------------	-----	-----	-----	-----	-----

Our prices are ex works!

## SNOW BLADE

WORKING WIDTH IN ANGLED POSITION  
WORKING WIDTH IN V-SHAPE  
WORKING WIDTH IN Y-SHAPE

150 cm	180 cm	210 cm	240 cm	260 cm	320 cm	370 cm
135 cm	161 cm	196 cm	214 cm	224 cm	265 cm	300 cm
135 cm	161 cm	199 cm	217 cm	226 cm	273 cm	281 cm
135 cm	160 cm	193 cm	211 cm	222 cm	257 cm	320 cm

- 1322 Roust carrier frame with **two hydraulically adjustable folding wings**  
**incl. spring flap elements** as overrun fuse, with overload protection via nitrogen blowhole (two double-acting hydraulic circuits required), edge deflectors (right & left) & infinitely variable height-adjustable castor wheels
- » 210 & 240 cm: Ø 200 x 50 mm welded steel heavy duty castor
  - » from 260 cm: Ø 250 x 80 mm)
- with **PU-lip** :  
with **cummunal lip** highly wear resistant rubber lip with corundum inlay:  
with **steel lip**:

3,608	4,050	4,752	5,662	5,955	6,662	7,695
4,123	4,597	5,343	6,409	6,773	7,435	8,738
3,958	4,469	5,242	6,210	6,544	7,386	8,522

## ATTACHMENT

**A-frame** CAT I incl. swivel console (see page 24)

» with screwed gibs for fixed attachment	1,121	1,121	1,302	1,302	1,302	1,302	1,538
» with side levelling	1,759	1,759	1,940	1,940	1,940	1,940	2,128
» incl. roller shaft (2-D levelling) and height indicator (=centre position in side levelling see Page 24)	1,875	1,875	2,072	2,072	2,072	2,072	2,283

**Three-point linkage** CAT I / II incl. swivel console (see Page 24)

» with screwed gibs for fixed attachment	1,214	1,214	1,395	1,395	1,395	1,395	1,632
» with side levelling	2,001	2,001	2,197	2,197	2,197	2,197	2,382
» incl. roller shaft (2-D levelling) and height indicator (=centre position in side levelling see Page 24)	2,126	2,126	2,343	2,343	2,243	2,343	2,554

**Wheel loader / telescopic loader attachment** (quick hitch system)

incl. swivel console with roller shaft (2-D levelling) & height indicator (=centre position in side levelling see Page 24)	2,157	2,157	2,374	2,374	2,374	2,374	2,610
--	-------	-------	-------	-------	-------	-------	-------

**Municipal vehicle attachment** (up to 180 cm)

Lift-out device on the vehicle side (Kommobil, Multicar, ...)							
» with screwed gibs for fixed attachment	1,005	1,005					
» with side levelling	1,790	1,790					

**Attachment plate with lifting** including swivel console, excavation cylinder with pressure limit, Level / side levelling and transport locking device

fits with **Unimog front mounting attachment DIN 76060** (from 210 cm)

» Shape B (size 3) with fastening via swivelling screws M30 or clamping screws M24							
» Shape A (size 5) with fastening via swivelling screws M30			3,181	3,181	3,181	3,181	3,181

**Fork-tines attachment** 150 x 50 mm incl. swivel console with screwed gibs

» with side levelling	1,270	1,270	1,451	1,451	1,451	1,451	1,687
» Surcharge for bigger fork-tine pockets (200 x 100 mm)	2,054	2,054	2,251	2,251	2,251	2,251	2,438
							219

## OPTIONS

**perfect control**

Wing adjustment in straight position right/left or from Y-shape to V-shape in one working step (only 1 "DW" required) (12/24 volt connection for switch box required)							1,620
---	--	--	--	--	--	--	-------

**electro-magnetic commutator** (EM) 12/24 V

(per additional hydraulic function) for vehicles with only one double-acting hydraulic circuit							887
--	--	--	--	--	--	--	-----

**skids** (price per pair) (from 210 cm)

	1,093	1,093	1,093	1,093	1,093	1,093
--	-------	-------	-------	-------	-------	-------

**extra strong wheels**

» 210 & 240 cm Ø 200 x 80 mm, steel welded, for heavy duty (price per pair)							320
» from 260 cm width <b>CSE tyres</b> Ø 306 x 116 mm (price per pair)							860

**limiting lights** (LED) acc. to StVZO (road traffic licensing authority) when driving in road traffic

345

**signal flag holder** (price per pair)

80

**signal flags** (price per pair)

41

**special colour** according to RAL (standard RAL 2004)

304

Transport & Packaging (net)	290	305	325	325	350	475	475
-----------------------------	-----	-----	-----	-----	-----	-----	-----

Our prices are ex works!

### SALT SPREADER

120 Litres

200 Litres

- 1301 » 12-V operation, ideal for vehicles which have no or little hydraulic performance
- » the central control unit, enables convenient control of the spread width and spread rate from the driver's seat
  - » equipped as standard with agitator unit (supported on both sides), this effects a breaking up and improvement of the salt flow & avoids bridge building
  - » the rotating speed is freely adjustable & secures optimal dosing
  - » complete, made of 2.5 mm stainless steel, for long durability
  - » PE spreader material container with level indicator and hand guard incl. loss-protected flap cover
  - » central throw shovel adjustment for calibration of the spread pattern
  - » Spreading width up to 6 m

3,243

3,702

### ATTACHMENT

**A-frame CAT I** (see page 24)

- » with screwed gibs for fixed attachment

336

**Three-point linkage CAT I / II / 1N** (see Page 24)

- » with screwed gibs for fixed attachment

280

**Hitch mounting** for wheel / yard loader and forklifts

unscrewable / height-adjustable, enables convenient hanging up and tilting of the salt spreader without disassembly of the trailer coupling

784

### OPTIONS

**lighting unit LED 12/24 V**

adjustable with direction indicator, brake light and rear lamp function

548

Transport & Packaging (net)

175

175

Our prices are ex works!

## BASIC MACHINE (immediately ready for operation)

Dimensions (W / H / L / kg)

W: 93 cm H: 130 cm L: 210 cm Weight: 642 kg / 680 kg

- 1601 » hydraulic four-wheel drive with two driving speeds (forward / backward) & agrarian traction tyres
- » hydraulic rear wheel steering
- » two double-acting hydraulic circuits at the front with a pressureless return flow
- » double-acting front linkage incl. quick hitch system (SWE) with floating position
- » GFK engine bonnet (can be set up)
- » Operating hours counter

### Kubota 2-cylinder diesel engine

10.3 kW (14 PS) at 3,200 rpm, water-cooled, electric starter, work hydraulics: max. 25 l/min at 170 bar

17,895

### Kubota 3-cylinder diesel engine

14.9 kW (20 PS) at 3,600 rpm, water-cooled, electric starter, work hydraulics: max. 28 l/min at 170 bar

19,128

## ACCESSORIES

<b>rear weight</b> 60 kg, screwed		579
<b>recovery eyelet</b> Hitch mounting with ball-shaped head		304
<b>LED working lights</b> front & rear		446
<b>tyre fill</b> (with heavy spreading materials)		
» Magnesium chloride for ballast (price per piece)	piece	137
» Polyurethane (PU), filling as breakdown protection and for ballasting	piece	236
<b>lawn tyres</b> to avoid crop damages		467
<b>motor heating system</b> 230 V		393
<b>hydraulic top link</b> optimal for working with a high-dump bucket, a double-acting hydraulic circuit required (not compatible with bedding tools)		420
<b>hydraulic 4-fold multi coupling</b> can be coupled under remaining pressure, for two double-acting hydraulic circuits (pressureless return flow not connected as well)		576
<b>special colour</b> according to RAL (standard RAL 2004)		625

Transport & Packaging (net)

450

Our prices are ex works!

# ATTACHMENTS

1643	<b>Bedding tool "E"</b> with auto fill Basic container 450l, conveyor belt with hydraulic drive (32 ccm engine), adjustable dosing slide, exterior, agitator shaft again bridge building, infinitely variable speed of the agitator shaft and the conveyor belt (for fine adjustment of the applied quantity) <b>Brush of the agitator shaft</b>	
	» <b>without side brush</b> (heavy spreading material, e.g. separated slurry; low stalls): 7 straight & 2 cranked fingers outside	
	» <b>with side brush</b> (fine spreading material, e.g. chopped straw, sawdust / shavings, raised stalls): 8 cranked fingers (7 straight fingers are delivered loose), container with dosing metal plate, inside	
	» <b>with side brush</b> (fine spreading material, e.g. straw meal; raised stalls): 4 bucket fingers, 2 cranked fingers outside & container with fine dosing metal plate, inside	
	(Upon consultation, other brushes possible in case of initial equipment)	6,505
	» <b>Attachment with auto fill</b> (hydr. tipping device); attachment to Trio	1,417
	» <b>Attachment without auto fill</b> : Attachment to Trio	537
	» <b>Cover</b> : protects spreading material against moisture (fits also with container extensions)	529
	» <b>Slurry scraper</b> : Working width 145 cm	530
	» <b>Side brush</b> : 100 % PP, hydraulically adjustable via hydraulic cylinder with tipping device (with raised stalls)	
	ø 750 mm	1,823
	ø 850 mm	1,958
	» <b>Container extension</b> , for increasing the container capacity (for light spreading material)	
	+ 170 l (total capacity 620 l)	202
	+ 375 l (total capacity 825 l) (restricted visibility)	353
	» <b>Quick hitch adapter</b> for TRIO (position of the bedding tool is farther at the front than with the standard version, shift of centre of gravity)	291
1623	<b>Bedding tool "F"</b> with external filling Basic container 160 l, conveyor screw, conveyor belt (drive 32 ccm engine) with continuous, fine adjustment of the speed	6,532
	» includes attachments for TRIO	537
	» <b>Slurry scraper</b> , Working width 145 cm	530
	» <b>Side brush</b> : Brush 100 % PP with hydraulic angular positioning via hydraulic cylinder with tipping device (with raised stalls)	
	ø 750 mm	1,947
	ø 850 mm	2,082
	» <b>Quick hitch adapter</b> for TRIO (enables quick change of various work tools)	291
1651	<b>Slurry scraper</b> 2-part, for V-shaped pushing, max. width 130 cm, height 35 cm, with adjustable double lip & quick hitch attachment	1,213
	» <b>hydraulic adjustment</b> of both slides (right / left; not possible in combination with the side brush)	288
	» <b>Side brush</b> : Brush 100 % PP with hydraulic angular positioning, ø 750 mm	1,487
2243	<b>Rubber slider</b> width 160 cm, hydraulic swivel device (right / left)	1,770
1631	<b>Food turner</b> 110 cm with quick hitch attachment for TRIO; hydraulic performance from 20 to max. 50 l/min. at 160 bar	3,299
	» <b>Concentrated feed distributor</b> as attachment to food turner	1,580
	» <b>Cover</b> for concentrated feed distributor	286
9004	» <b>Yard loader attachment</b> with height adjustment via parallelogram	1,194
1162	<b>Road sweeper Simplex</b> 120 cm	(see page 2)
1192	<b>Snow blade L-SK</b> 125 cm	(see page 13)
2009	<b>Radial brush</b> ø 1200 mm 100 % PP, hydraulically driven, with right-hand / left-hand rotation, swath guard & quick hitch attachment	2,032
2326	» with <b>feed baffle plate</b> (right)	2,498
1662	<b>Mulch mower</b> 110 cm 2 mulching blades, hydraulic drive via two individual hydraulic motors (required oil quantity: 25 l/min at 150 bar), 4 castor wheels ø 180 x 50 mm, height adjustment via spacer rings on the castor wheels, 3-D levelling & quick hitch attachment for TRIO	3,073
1665	<b>Weed Brush</b> ø 750 mm hydraulic swivel device (right / left), parking support, circular brush right-hand / left-hand rotation, with mechanical inclination adjustment, 2 height-adjustable support wheels ø 150 x 50 mm, variable rubber protection cloth	
	» Circular brush 100% flat steel	1,706
	» Circular brush flat steel bundle and flat steel	1,977
	» Circular brush, 2-row flat steel bundle	1,932
1685	<b>High-dump bucket</b> 102 cm (for light materials) Volume: 210 l, can be hydraulically dumped, optimal with hydraulic top link on the Trio (see Page 20)	1,795
1682	<b>Pallet fork</b> Width 90 cm, ISO/FEM 1, prongs 8 x 2.5 x 80 cm, optimal with hydraulic top link at Trio (see page 20)	1,221
	» Prong protection for road traffic	164
	<b>Hydraulic 4-fold multi coupling</b> for attachments can be coupled under remaining pressure, only for 2 double-acting hydraulic circuits, not for pressureless Return flow, with bedding tool E/F only in connection with quick hitch adapter (price per attachment)	566

Transport & Packaging (net)

190

Our prices are ex works



### BASIC MACHINE (immediately ready for operation)

Dimensions (W / H / L / kg)

W: 85 m H: 175cm L: 169 cm Weight: 290 kg

- 1676 » **Honda GXV 390 1-cylinder petrol engine**, 7.6 KW (10.2 PS) at 3,600 rpm, (air-cooled, electric starter, rope pull starter)
- » Work hydraulics: max. 11 l/min at 170 bar
  - » Front-wheel drive
  - » Agrarian traction tyres
  - » powerful, robust hydro start
  - » mechanical rear wheel steering (steering via steering linkage)
  - » a double-acting hydraulic circuit at the front
  - » single-acting front linkage with quick hitch system (SWE) incl. floating position
  - » Operating hours counter

8,661

### ACCESSORIES

<b>tyre fill</b>		
» Polyurethane (PU), filling as breakdown protection and for ballasting	piece	158
<b>special colour</b> according to RAL (standard RAL 2004)		304

### 1446 ATTACHMENTS

<b>Bedding tool "EL"</b> with electric drive (24 V) battery-operated, switch-on time max. 30 min., incl. charger, for materials such as: Sawdust, straw meal, lime, incl. infinitely adjustable dosing slide, variable speed regulation of the conveyor, discharge in driving direction on the right, mounted on the rear		
» Volume 48 litres		3,325
» Volume 150 litres (not suitable for lime)		3,728
<b>Slurry scraper 105 cm</b> V-shape, double lip with low-wear PU-lips ensures easy and rapid cleaning of slatted floors		602
» with side brush ø 600 mm, 100 % PP brush mounted on slurry scraper, hydraulically swivelling, mechanically height-adjustable		1,856
<b>Feed pusher / snow blade 135 cm</b> swivelling right and left (mechanical) with low-wear scrape rail for optimal resubmission of the feed and simultaneous cleaning of the feeding table, also suitable for snow removal		628
» with hydraulic angling		961
<b>Road sweeper 100 cm</b> Brushes ø 320 mm, 100 % PP brush, side levelling, internal hydraulic motor, castor wheels ø 140 mm, incl. splash guard for free-sweeping version		1,296
» Collecting container, can be mechanically emptied, incl. free-sweeping mode		378
<b>Radial brush ø 1050 mm</b> 100 % PP, hydraulically driven, with right-hand / left-hand rotation		995
» with feed baffle plate (left) for optimal clearing of feed		1,141
» Surcharge for a swath guard (left)		123
<b>Weed Brush ø 750 mm</b> with mechanical swivel device (right / left), parking support, circular brush right-hand / left-hand rotation incl. mechanical inclination adjustment & variable rubber protection cloth		
» Circular brush 100% flat steel		1,261
» Circular brush flat steel bundle and flat steel		1,529
<b>High-dump bucket</b> Width: 87 cm, capacity: 50 l, can be hydraulically dumped		897

<b>Tuchel Trac Mini 3,</b>	
» Transport & Packaging (net)	330
<b>Attachment devices</b>	
» Transport & Packaging (net)	on demand

Our prices are ex works!

## BASIC MACHINE (immediately ready for operation)

Dimensions (W / H / L / kg)

W: 61 cm H: 104 cm L: 109 cm Weight: 84 kg

- 1432 » **Honda GCV 160 petrol engine**, 3.3 KW (4.5 PS) at 3,200 rpm, (air-cooled, rope pull starter)
- » Hydraulic performance: 6 l/min at 3,200 rpm,
  - » hydraulic drive with one driving speed (forward / backward) boom control
  - » Agrarian traction tyres
  - » a double-acting hydraulic circuit

2,859

### ACCESSORIES

<b>travel drive</b> continuous up to 3.7 km/h, control via rod assembly & adjustment wheel (no Bowden cables)	517
<b>special tyres</b> extra wide agrarian traction tyres 16 x 6.50 x 8 (ø 400 mm)	281

### 1441 ATTACHMENTS

<b>Slurry scraper</b> 100 cm V-shape, double lip with low-wear Diepothan strips ensures easy and rapid cleaning of slatted floors	680
<b>Feed pusher blade</b> 110 cm with low-wear scrape rail for optimal resubmission of the feed, simultaneous cleaning of the feeding table, also suitable for snow removal, side levelling, swivelling right and left & powder-coated	666
<b>Snow blade</b> 95 cm with low-wear scrape rail, side levelling, swivelling right and left & powder-coated	527
<b>Axial sweeper</b> Brushes ø 320 mm with 100 % PP brush, hydraulic motor, side levelling, swivelling right and left & powder-coated	
» 75 cm	1,126
» 100 cm	1,443
<b>Collecting container</b> with scrape rail	
» 75 cm	346
» 100 cm	551
<b>Radial brush</b> ø 800 mm 100 % PP brush bristles, hydraulically driven & right-hand / left-hand rotation	1,323
<b>Weed Brush</b> ø 600 mm Circular brush 100% flat steel, hydraulically driven & right-hand / left-hand rotation	1,304
<b>Bedding tool "EL"</b> with electric drive (24 V) battery-operated, switch-on time max. 30 min., incl. charger, for materials such as: Sawdust, straw meal, lime; incl. infinitely adjustable dosing slides, variable speed regulation of the conveyor, discharge in driving direction on the right, Attachment via own chassis	
» Volume 48 litres	3,342

<b>Tuchel Farm-Clean,</b> » Transport & Packaging (net)	175
<b>Attachment devices</b> » Transport & Packaging (net)	on demand
Our prices are ex works!	

A-FRAME

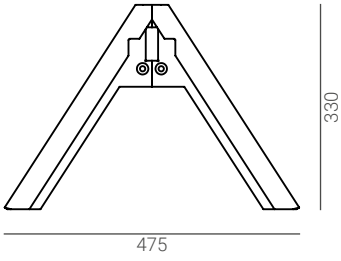

CAT COMMUNAL

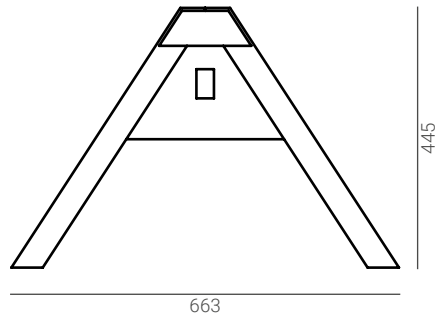

CAT 0

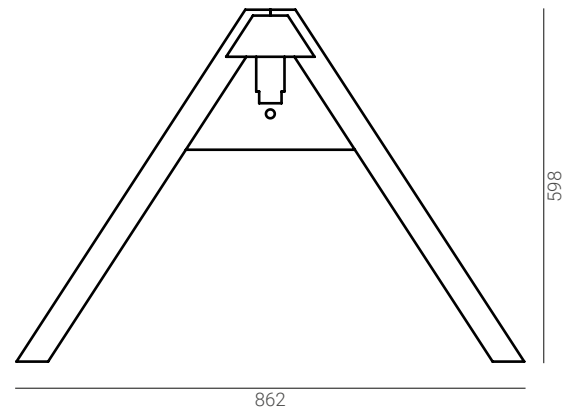

CAT I

THREE-POINT LINKAGE

CAT I / II

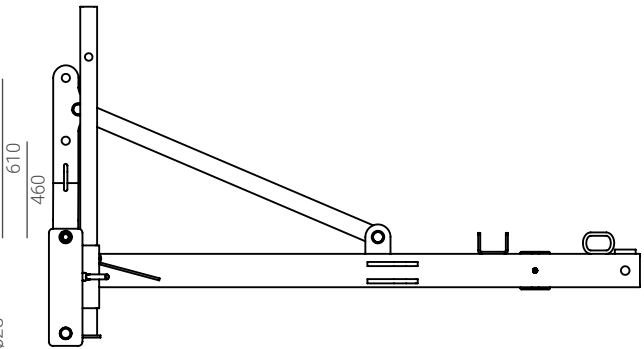
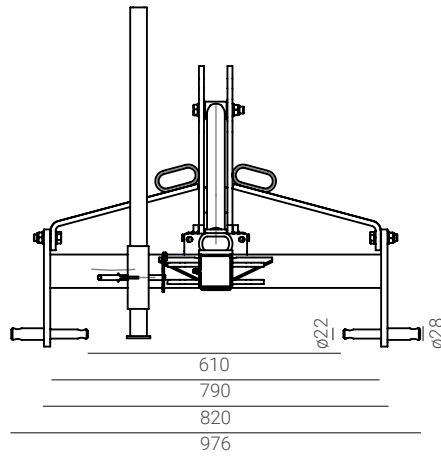
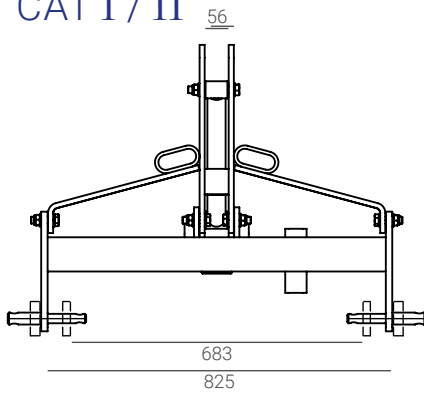

CAT I N

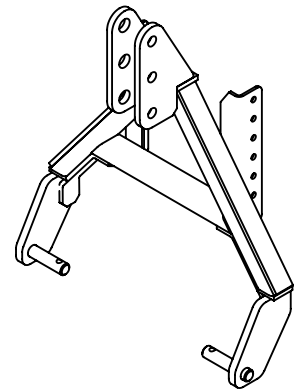
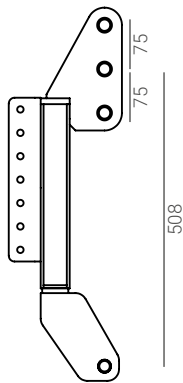
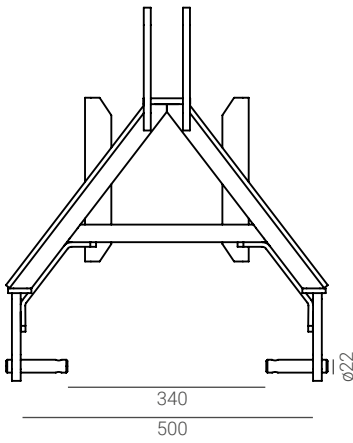

3-D LEVELLING

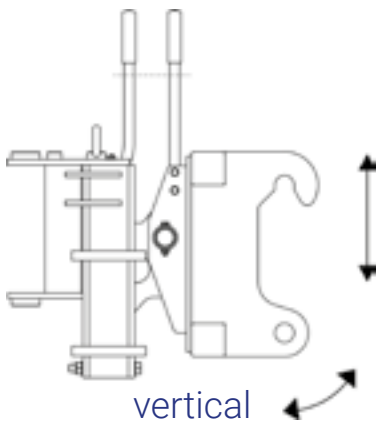

vertical

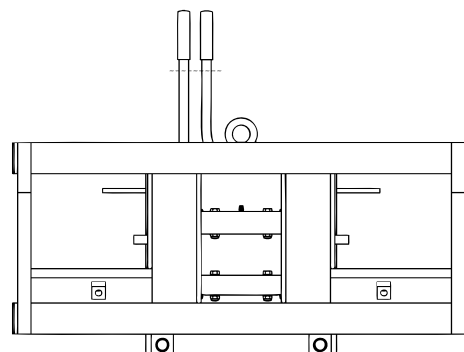

horizontal

BRUSH

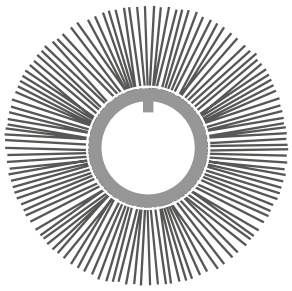

WaveLine

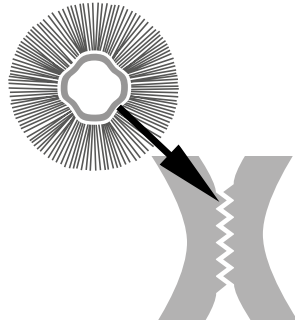

WaveLine with CrownLock

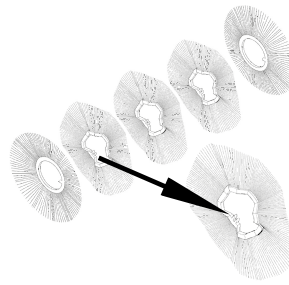

Beeline



PP or PP/wire



Snowline



Brushes

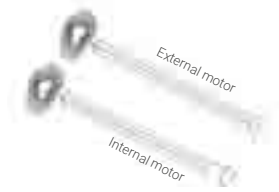

Roller shaft for brush rings



Roller shaft for brushes

HYDRAULIC COUPLING

SVK PLUG COUPLING

PLUG

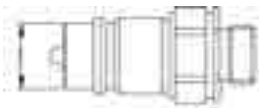

- Size 2 =  $\varnothing$  17.2 mm
- Size 3 =  $\varnothing$  20.5 mm
- Size 4 =  $\varnothing$  29 mm

SLEEVE

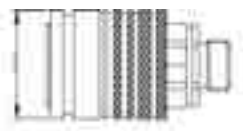

- Size 2 =  $\varnothing$  31 mm
- Size 3 =  $\varnothing$  38 mm
- Size 4 =  $\varnothing$  48 mm

SCREW COUPLING

PLUG

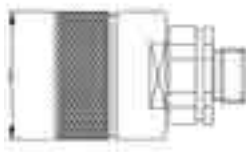

- Size 1 =  $\varnothing$  35 mm
- Size 3 =  $\varnothing$  42 mm
- Size 4 =  $\varnothing$  48 mm
- Size 5 =  $\varnothing$  55 mm

SLEEVE

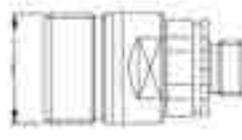

- Size 1 =  $\varnothing$  M 24x2
- Size 3 =  $\varnothing$  M 36x2
- Size 4 =  $\varnothing$  M 42x2
- Size 5 =  $\varnothing$  M 48x3

FLAT FACE COUPLING (drip-free)

PLUG

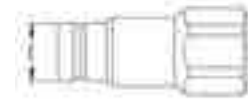

- Size 1 =  $\varnothing$  16.1 mm
- Size 2 =  $\varnothing$  19.7 mm
- Size 3 =  $\varnothing$  24.5 mm
- Size 4 =  $\varnothing$  30 mm

SLEEVE

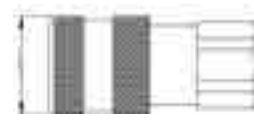

- Size 1 =  $\varnothing$  28 mm
- Size 2 =  $\varnothing$  32 mm
- Size 3 =  $\varnothing$  38 mm
- Size 4 =  $\varnothing$  48 mm

Evogreen srl - Rue du Bois 44 - B-4840 Welkenraedt

Tel: +32 (0)493 39 00 30 - Fax: +32 (0)87 88 19 99

info@evogreen.be - www.evogreen.be

Contact

Do not hesitate to contact us !



SALES REPRESENTATIVE  
FOR WALLONIA  
**Raphaël Nix**

+32 (0)493 39 00 33  
raphael@evogreen.be



SALES REPRESENTATIVE  
FOR FLANDERS  
**Bert Nickmans**

+32 (0)493 39 00 32  
bert@evogreen.be



ADMINISTRATION  
**Christine Stassen**

+32 (0)493 39 00 30  
admin@evogreen.be



AFTER SALES SERVICES  
**Robert Habets**

+32 (0)493 39 00 31  
support@evogreen.be

# HIGH QUALITY



MADE IN GERMANY

## **Tuchel Maschinenbau GmbH**

Holsterfeld 15

D-48499 Salzbergen

+49 (0) 5971 96 75 0

+49 (0) 5971 96 75 30

[info@tuchel.com](mailto:info@tuchel.com)



\* All previous prices are no longer valid! Subject to material surcharge and toll charge! Dimensions, weights and technical data subject to correction.

**Note:** The hydraulic couplings are selected according to manufacturer or customer specifications. But they are NOT included in the scope of delivery and must be replaced by the customer themselves.

**Note:** Resulting from the manufacturing process, wire bristles can come loose or break off. In sensitive areas, this can lead to injuries. We shall not assume any liability for that!